

MAMMUT

T R U E S A F E T Y F U L L P O W E R

2026
CATALOGUE
CATALOGO

A B R A N D B Y
Cattini
OLEOPNEUMATICA





1967

Cattivini
OLEOPNEUMATICA



WWW.CATTINI.EU



ABOUT US FILOSOFIA

For over 55 years our company has been working in the air-hydraulic sector with an ever-increasing qualitative and technological growth, offering an extremely wide range of products. Our jacks have proved themselves over the years thanks to their outstanding reliability and long life, not to mention their elegance and practicality. Manufactured using the highest quality materials, the jacks are all individually tested and inspected before leaving our factory. This enabled us to achieve high market shares in the main European and global markets.

Da oltre 55 anni, la nostra azienda opera nel settore dell'oleopneumatica con una crescita qualitativa e tecnologica sempre maggiore, fornendo una gamma estremamente vasta di prodotti. I nostri sollevatori si sono contraddistinti negli anni per la loro elevata affidabilità e durata nel tempo, nonché per la loro praticità e design. Costruiti con materiali di primissima qualità, ogni sollevatore viene collaudato e testato prima di lasciare la nostra fabbrica. Questo ci ha permesso di guadagnare elevate quote sui principali mercati europei e nel resto del mondo.

PRODUCTION PLANT STABILIMENTO PRODUTTIVO

It is located on a total area of around 4500 sqm. The highly automated production management allows the fast delivery of any type of jack, thus meeting the requirements of all our customers in very short time.

Dislocato su un'area complessiva di circa 4500 m². Dalla gestione altamente informatizzata, permette la consegna rapida di qualsiasi tipo di sollevatore nell'immediata soddisfazione delle richieste di tutti i nostri clienti.



CERTIFICATION CERTIFICAZIONI

Our company is certified according to the ISO 9001 QUALITY MANAGEMENT SYSTEM. At present, all our products comply with the directives 93/44/EEC, EN1494, 98/37/EEC, 2006/42/EEC, EAC and TÜV.

L'azienda è certificata secondo il sistema ISO 9001 QUALITY MANAGEMENT SYSTEM. Attualmente i nostri prodotti sono conformi alle direttive 93/44/EEC, EN1494, 98/37/EEC, 2006/42/EEC, EAC e TÜV.



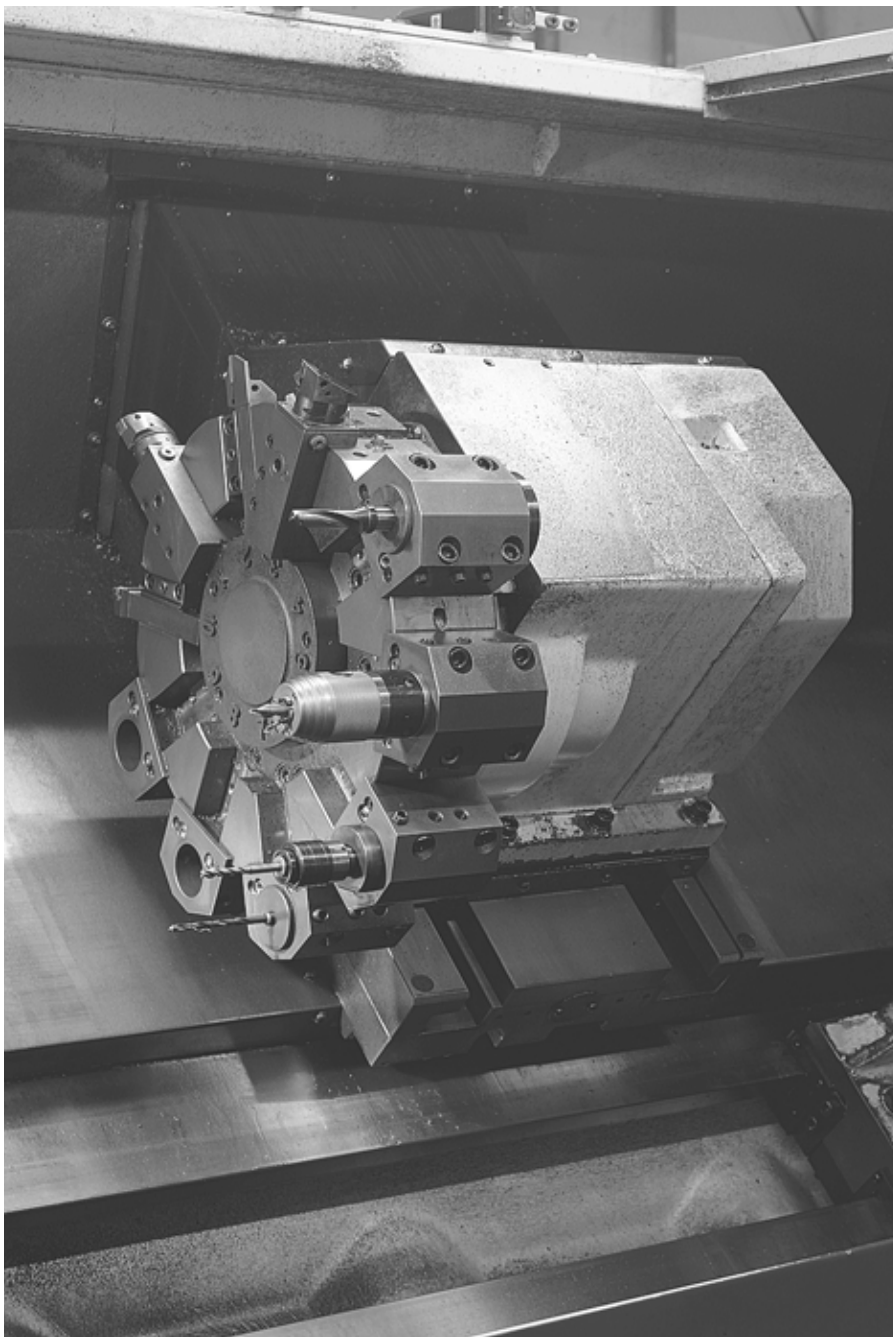

KNOW HOW ESPERIENZA

The search for maximum product quality is the result of a high level of professionalism and over 55 years experience in the field, combined with the great expertise of our staff. All design phases are carried out in-house using cutting-edge computer systems, 3D graphics software and vector programs.

La ricerca della massima qualità scaturisce da un elevato grado di professionalità e ultra cinquantennale esperienza sul campo, unita alla grande professionalità del nostro personale. Tutte le fasi della progettazione sono eseguite internamente utilizzando sistemi informatici estremamente avanzati, software di grafica 3D e programmi vettoriali.

SUSTAINABILITY SOSTENIBILITÀ

We adopt a sustainable approach to production, based on ethical responsibility and environmental respect. Manufacturing in Italy ensures compliance with very strict regulations. We ensure that maximum durability is our priority since the early stages of the the jack design, selecting excellent materials and advanced technologies. We also offer repair services to guarantee that the jack remains in service for many years. With this approach we significantly reduces waste and energy consumption. Also our painting system is specifically designed and built for the use of water-based eco friendly materials.

L'azienda adotta un approccio sostenibile alla produzione, basato su responsabilità etica e rispetto ambientale. Produrre in Italia garantisce il rispetto di normative molto rigorose. La nostra priorità durante la progettazione dei sollevatori è assicurare la massima durabilità, utilizzando materiali eccellenti e tecnologie avanzate, oltre a offrire servizi di riparazione per prolungarne la vita. Questo metodo riduce significativamente rifiuti ed energia consumata. Inoltre, il nostro impianto di verniciatura interno è stato progettato e realizzato appositamente per la verniciatura ecologica dei nostri prodotti con vernici ad acqua.

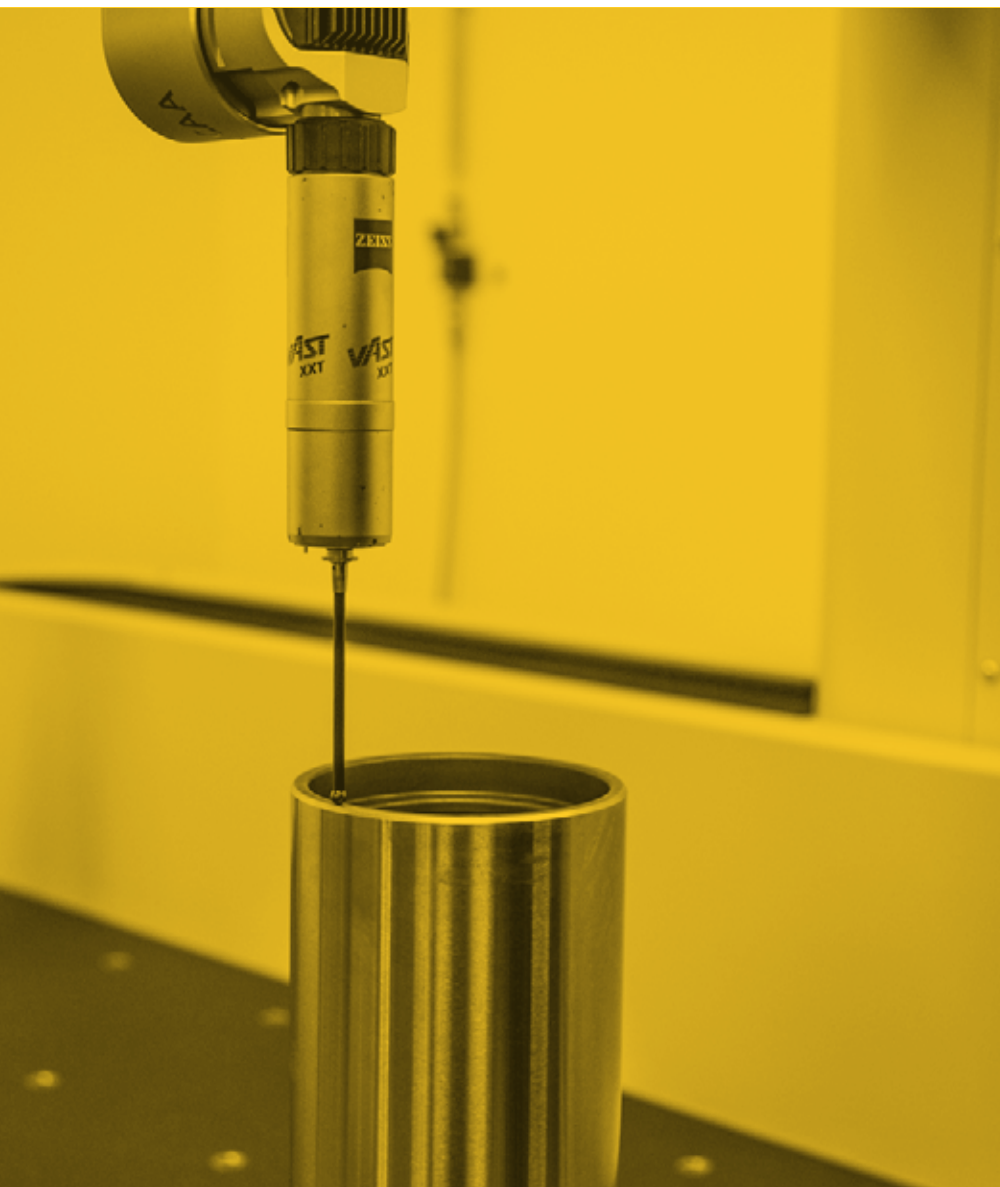

QUALITY CONTROL CONTROLLO QUALITÀ

We believe that quality is a fundamental value that starts with the material selection. All our products are supplied with certified technical data sheets with mechanical specifications and detailed chemical analysis. The quality control process is carefully applied through every single stage of the manufacturing up to the final presentation of the finished product. With this approach, we are able to guarantee reliable and durable jacks, confirming our efficiency and constant commitment.

La qualità, per noi, rappresenta un valore fondamentale che si concretizza sin dalla selezione dei materiali. Ogni fornitura è accompagnata da schede tecniche certificate, contenenti specifiche meccaniche e analisi chimiche dettagliate. Il controllo, tuttavia, non si limita a questa fase preliminare: accompagna l'intero processo produttivo fino alla presentazione del prodotto finito. Grazie a questo approccio, siamo in grado di garantire sollevatori affidabili e duraturi, confermando la nostra serietà e il nostro impegno costante.



WORKING THE RAW MATERIALS LAVORAZIONE MATERIE PRIME

The working of each single item is done entirely in-house, using high precision numerically controlled machinery. Once the first steps have been completed, the product is ready for surface heat treatments, followed by a further check to verify its compliance with quality standards.

La lavorazione dei singoli particolari è eseguita interamente all'interno dell'azienda utilizzando macchinari a controllo numerico di alta precisione. Terminati i primi passaggi, il prodotto è pronto per trattamenti termici superficiali, al termine dei quali viene nuovamente controllato per verificarne la conformità agli standard qualitativi.

ASSEMBLY ASSEMBLAGGIO

Highly qualified personnel carry out the assembly directly in our facilities, guaranteeing an additional control of every single part and, hence, of the jack.

Personale altamente qualificato esegue l'assemblaggio direttamente all'interno della nostra struttura, garantendo un ulteriore controllo di ogni singolo particolare e quindi di tutto il sollevatore.

FINAL TESTING AND INSPECTION ASSEMBLAGGIO

Each single jack produced undergoes final testing and inspection for more than an hour with automatic devices besides the ordinary tests established by the European Standards. It is then checked once again to ensure its perfect working order before being packed and shipped.

Ogni singolo sollevatore prodotto viene collaudato per oltre un'ora con dispositivi automatici, oltre alle normali prove imposte dalla Normativa Europea, e successivamente ricontrollato per garantirne il perfetto funzionamento prima di essere imballato e spedito.



WARRANTY GARANZIA

At Cattini, all efforts are made to assure our products meet high quality and durability standards. The Mammut range is covered by a 12 month warranty, valid from the date appearing on the purchase document. The warranty certificate can be found in the end user manual provided along with the shipment.

In Cattini, l'obiettivo principale è focalizzato sulla sicurezza. La gamma Mammut è coperta da 12 mesi di garanzia, valida a partire dalla data indicata sul documento d'acquisto. Il certificato di garanzia può essere trovato nel manuale di utilizzo per l'utente fornito insieme alla spedizione.

MINING AND SPECIAL APPLICATIONS JACKS SOLLEVATORI DA MINIERA E PER APPLICAZIONI SPECIALI

MAMMUT jacks are a safe and efficient lifting solution, suitable for vehicle maintenance in the mining, industrial, rail, construction, port and military industries.

Air-hydraulic operated, all models are equipped with double descent valve for a better control and a safer holding under load, with automatic piston return.

MAMMUT series has been designed to ensure excellent handling in use and transport, featuring:

- Extremely light, compact and easy to handle.
- Handlebar adjustable to 3 different positions for easy access and positioning under the vehicle to be lifted.
- Folding handlebar, which reduces the amount of space required when the jack is transported or not in use.
- Large pneumatic wheels, able to adapt to any ground.
- Special hooks that allow for safe lifting and easy transport.

The new MAMMUT series features several functional improvements in both operating safety and lifting performance, with the introduction of the remote control as standard and the new HPM motor pump.

Available in a variety of models depending on lifting capacity and use, all jacks can be fitted with a wide range of accessories:

- Load Blocking System (LBS)
- Extensions and extension holders
- Tilting plates

I sollevatori della linea MAMMUT offrono una soluzione di sollevamento sicura ed efficiente adatta alla manutenzione dei mezzi nei settori minerario, industriale, ferroviario, edile, portuale e militare.

Tutti i modelli sono oleopneumatici, con doppia valvola di discesa per un maggior controllo e una maggiore tenuta sotto carico e provvisti di rientro automatico dei pistoni.

Ideati e progettati per conferire un'eccellente manovrabilità durante l'utilizzo e il trasporto, ciascun sollevatore dispone di:

- Caratteristiche di estrema leggerezza, compattezza e maneggevolezza.
- Manico regolabile con 3 differenti posizioni per facilitarne l'inserimento e il posizionamento sotto al veicolo che si vuole sollevare.
- Manico ripiegabile che consente di ridurre lo spazio del sollevatore quando viene trasportato o non è utilizzato.
- Grandi ruote pneumatiche capaci di adattarsi a qualsiasi tipo di terreno.
- Ganci speciali per essere sollevato e trasportato con la massima semplicità e sicurezza.

La nuova serie MAMMUT è caratterizzata da diversi miglioramenti funzionali sia nella sicurezza di utilizzo che nelle performance di sollevamento, con l'introduzione di un comando remoto di serie e della nuova motopompa "HPM" per la maggior parte dei modelli.

Disponibili in vari modelli a seconda delle capacità e degli utilizzi, tutti i sollevatori possono essere configurati con una vasta gamma di accessori:

- Sistema di bloccaggio del carico. (LBS)
- Prolunghe e porta prolunghe.
- Piattelli basculanti.

A close-up, low-angle shot of the undercarriage of a large truck, showing the heavy-duty metal frame and a large, treaded tire. The truck is parked on a dirt surface. The text 'AIR-HYDRAULIC JACKS' is overlaid in white, bold, sans-serif font on the left side of the image.

**AIR-HYDRAULIC
JACKS**

***SOLLEVATORI
OLEOPNEUMATICI***



HPM

HIGH - PERFORMANCE - MOTORPUMP

The HPM motor pump, fitted on the M80/31, M80/42 and M100/40 jack, is the technological evolution of the previous version. Made of special materials to prevent corrosion and deformation even with intensive use and in adverse environments, it is free of any plastic parts to ensure long life and high performance. With a performance improvement between 40% and 95% in terms of speed under load, and a frequency increased by 108%, it provides faster and more effective lifting even in the most severe conditions. Designed and produced entirely in-house, it is the maximum technological evolution of our jacks.

La motopompa "HPM" introdotta nei sollevatori M80/31, M80/42 ed M100/40 è l'evoluzione tecnologica della precedente. Creata con materiali speciali per prevenire ruggine e deformazioni anche con uso intensivo e in ambienti ostili, è priva di qualsiasi parte in plastica per garantire longevità e prestazioni elevate. Con un aumento delle prestazioni tra il 40% e il 95% in termini di velocità sotto carico, e con una frequenza aumentata del 108%, garantisce un sollevamento più veloce ed efficace anche nelle condizioni più difficili. Progettata e prodotta interamente all'interno della nostra azienda, rappresenta la massima evoluzione tecnologica dei nostri sollevatori.



Air-hydraulic jack engineered and manufactured to offer a solution that is safe and easy to use.

Main features:

- light, compact, easy to handle
- folding handle
- pneumatic tyres for any surface

Sollevatore oleopneumatico progettato e costruito per offrire una soluzione sicura e di facile utilizzo.

Caratteristiche principali:

- *estrema leggerezza, compattezza e maneggevolezza*
- *manico pieghevole*
- *ruote pneumatiche per ogni superficie*

M60-22

**SUITABLE FOR
ADATTO A**

Mine and oil field / Construction site
Industrial assembly / Agriculture / Railway applications / Military
*Miniera e giacimento petrolifero / Cantiere
Assemblaggio industriale / Agricoltura / Applicazioni ferroviarie / Militare*



	Capacity Portata	Net weight Peso netto	Working air press. Press. di alimentazione	Air consumption Consumo d'aria	Max. height Altezza max.	Min. height Altezza min.	Number of pistons Numero sfili	Stroke Corsa
M60-22	60/30 t 66.1/33.1 ton	93 kg 205 lb	10 - 12 bar 145 - 174 psi	600 Nl/min	448 mm 17.6 in	222 mm 8.7 in	2	226 mm 8.9 in

Dimensions - Dimensionali

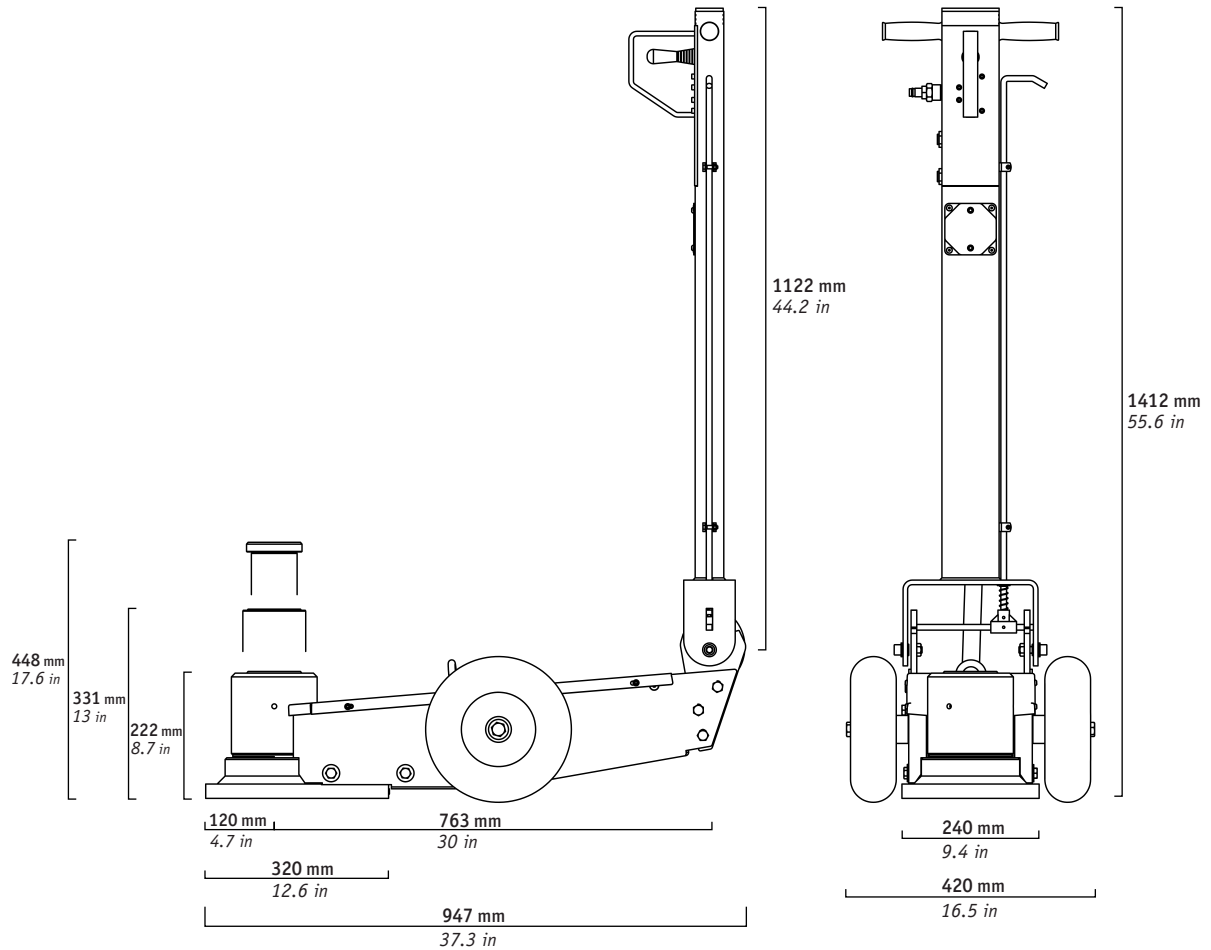

Accessories - Accessori

Code
Codice

Description
Descrizione

A00452	Remote control Comando Remoto
A06054	Extension Holder L Portaprolunghe SX
A06053	Extension Holder R Portaprolunghe DX
A04405	Extension Prolunga A: 80 mm B: 35 mm C: 20 mm D: 97 mm
A02432	Extension Prolunga A: 150 mm B: 35 mm C: 20 mm D: 97 mm
A02434	Extension Prolunga A: 250 mm B: 35 mm C: 20 mm D: 97 mm
A02436	Extension Prolunga A: 300 mm B: 35 mm C: 20 mm D: 97 mm
A08230	Extension with tilting plate Prolunga con piattello basculante A: 150 mm B: 35 mm C: 20 mm D: 97 mm
A08232	Extension with tilting plate Prolunga con piattello basculante A: 250 mm B: 35 mm C: 20 mm D: 97 mm
A08234	Extension with tilting plate Prolunga con piattello basculante A: 300 mm B: 35 mm C: 20 mm D: 97 mm
A04492	Tilting plate Piattello basculante A: 46 mm B: 35 mm C: 20 mm D: 97 mm



A00452



A06054



A06053



A04405



A02432



A02434



A02436



A08230



A08232



A08234



A04492

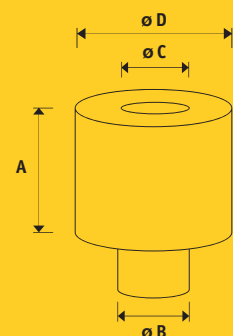



HPM
HIGH - PERFORMANCE - MOTORPUMP



YouTube



Air-hydraulic jack engineered and manufactured to offer a solution that is safe and easy to use.

Main features:

- High Performance Motorpump (HPM)
- light, compact, easy to handle
- folding handle
- standard remote control
- standard air filter
- pneumatic tyres for any surface

Sollevatore oleopneumatico progettato e costruito per offrire una soluzione sicura e di facile utilizzo.

Caratteristiche principali:

- *motopompa ad alte prestazioni (HPM)*
- *estrema leggerezza, compattezza e maneggevolezza*
- *manico pieghevole*
- *comando remoto di serie*
- *filtro aria di serie*
- *ruote pneumatiche per ogni superficie*



M80-31

SUITABLE FOR
ADATTO A

Mine and oil field / Construction site
Industrial assembly / Agriculture / Railway applications / Military
*Miniera e giacimento petrolifero / Cantiere
Assemblaggio industriale / Agricoltura / Applicazioni ferroviarie / Militare*



NEW AIR FILTER
NUOVO FILTRO ARIA



	Capacity Portata	Net weight Peso netto	Working air press. Press. di alimentazione	Air consumption Consumo d'aria	Max. height Altezza max.	Min. height Altezza min.	Number of pistons Numero sfili	Stroke Corsa
M80-31	80/50/25 t 88.2/55.1/27.6 ton	162 kg 357 lb	10 - 12 bar 145 - 174 psi	600 NI/min	848 mm 33.4 in	342 mm 13.5 in	3	506 mm 19.9 in

Dimensions - Dimensionali

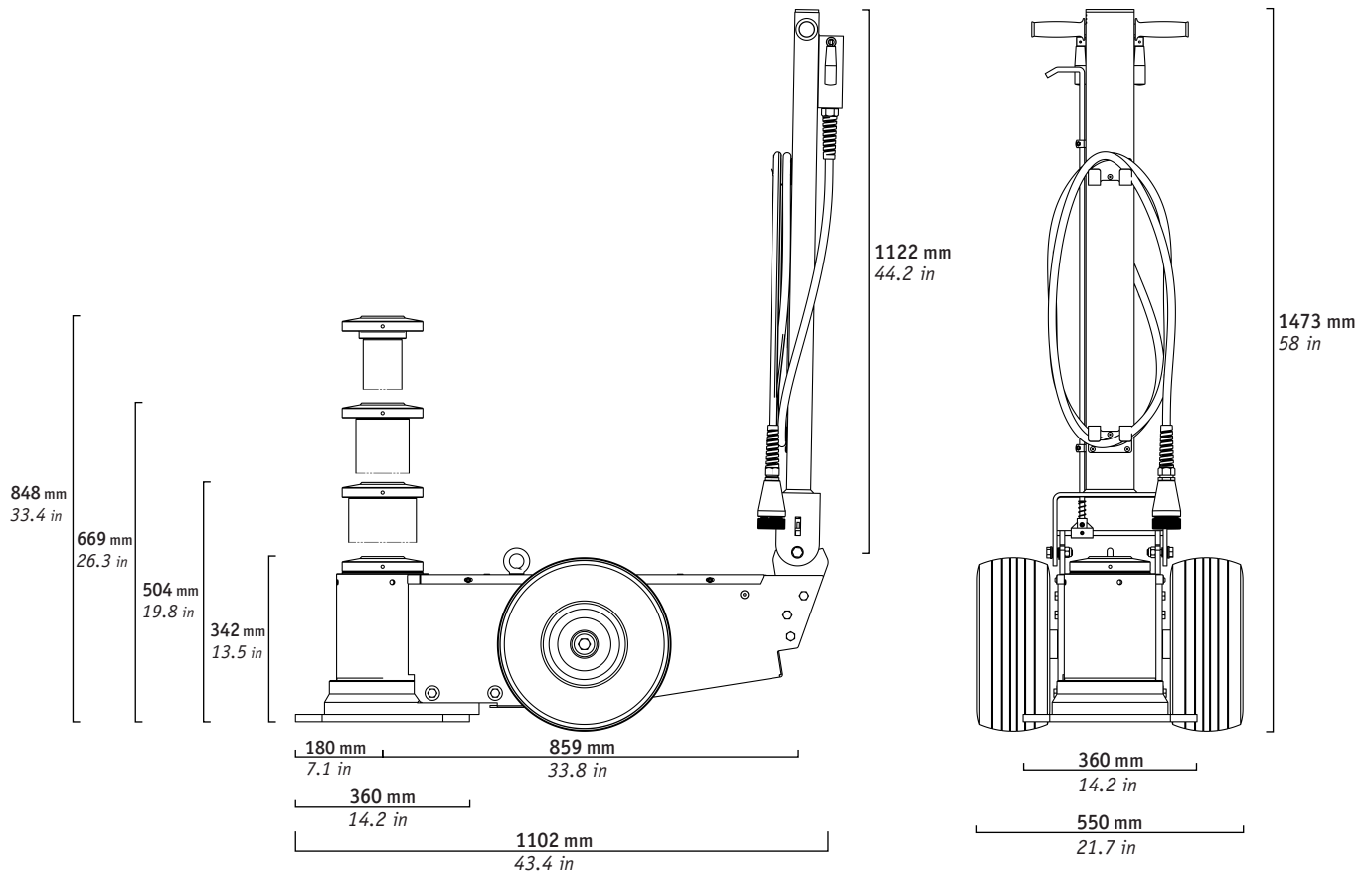

Accessories - Accessori

Code
Codice

Description
Descrizione

A00790	Safety Blocks Kit Kit Blocchi di Sicurezza
A06054	Extension Holder L Portaprolunghe SX
A06053	Extension Holder R Portaprolunghe DX
A04405	Extension Prolunga A: 80 mm B: 35 mm C: 20 mm D: 97 mm
A02432	Extension Prolunga A: 150 mm B: 35 mm C: 20 mm D: 97 mm
A02434	Extension Prolunga A: 250 mm B: 35 mm C: 20 mm D: 97 mm
A02436	Extension Prolunga A: 300 mm B: 35 mm C: 20 mm D: 97 mm
A08230	Extension with tilting plate Prolunga con piattello basculante A: 150 mm B: 35 mm C: 20 mm D: 97 mm
A08232	Extension with tilting plate Prolunga con piattello basculante A: 250 mm B: 35 mm C: 20 mm D: 97 mm
A08234	Extension with tilting plate Prolunga con piattello basculante A: 300 mm B: 35 mm C: 20 mm D: 97 mm
A04492	Tilting plate Piattello basculante A: 46 mm B: 35 mm C: 20 mm D: 97 mm



A00790 KIT:

- 1x Safety Blocks Holder - *Portablocchi*
- 1x Vertical Safety Blocks Holder - *Portablocchi verticale*
- 1x Eyebolt Extension - *Prolunga golfare*
- 4x Safety Block - *Blocco di sicurezza - H100 - 177 mm*
- 1x Safety Block - *Blocco di sicurezza - H50 - 177 mm*

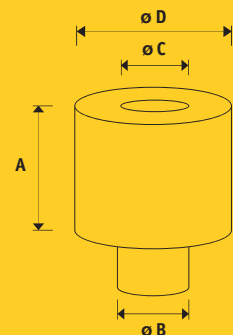



Air-hydraulic jack engineered and manufactured to offer a solution that is safe and easy to use.

Main features:

- High Performance Motorpump (HPM)
- light, compact, easy to handle
- folding handle
- standard remote control
- standard air filter
- pneumatic tyres for any surface

Sollevatore oleopneumatico progettato e costruito per offrire una soluzione sicura e di facile utilizzo.

Caratteristiche principali:

- *motopompa ad alte prestazioni (HPM)*
- *estrema leggerezza, compattezza e maneggevolezza*
- *manico pieghevole*
- *comando remoto di serie*
- *filtro aria di serie*
- *ruote pneumatiche per ogni superficie*



M80-42

SUITABLE FOR
ADATTO A

Mine and oil field / Construction site
Industrial assembly / Agriculture / Railway applications / Military
Miniera e giacimento petrolifero / Cantiere
Assemblaggio industriale / Agricoltura / Applicazioni ferroviarie / Militare



NEW AIR FILTER
NUOVO FILTRO ARIA



	Capacity Portata	Net weight Peso netto	Working air press. Press. di alimentazione	Air consumption Consumo d'aria	Max. height Altezza max.	Min. height Altezza min.	Number of pistons Numero sfili	Stroke Corsa
M80-42	80/50 t 88.2/55.1 ton	173 kg 381 lb	10-12 bar 145-174 psi	600 NI/min	824 mm 32.4 in	419 mm 16.5 in	2	420 mm 16.5 in

Dimensions - Dimensionali

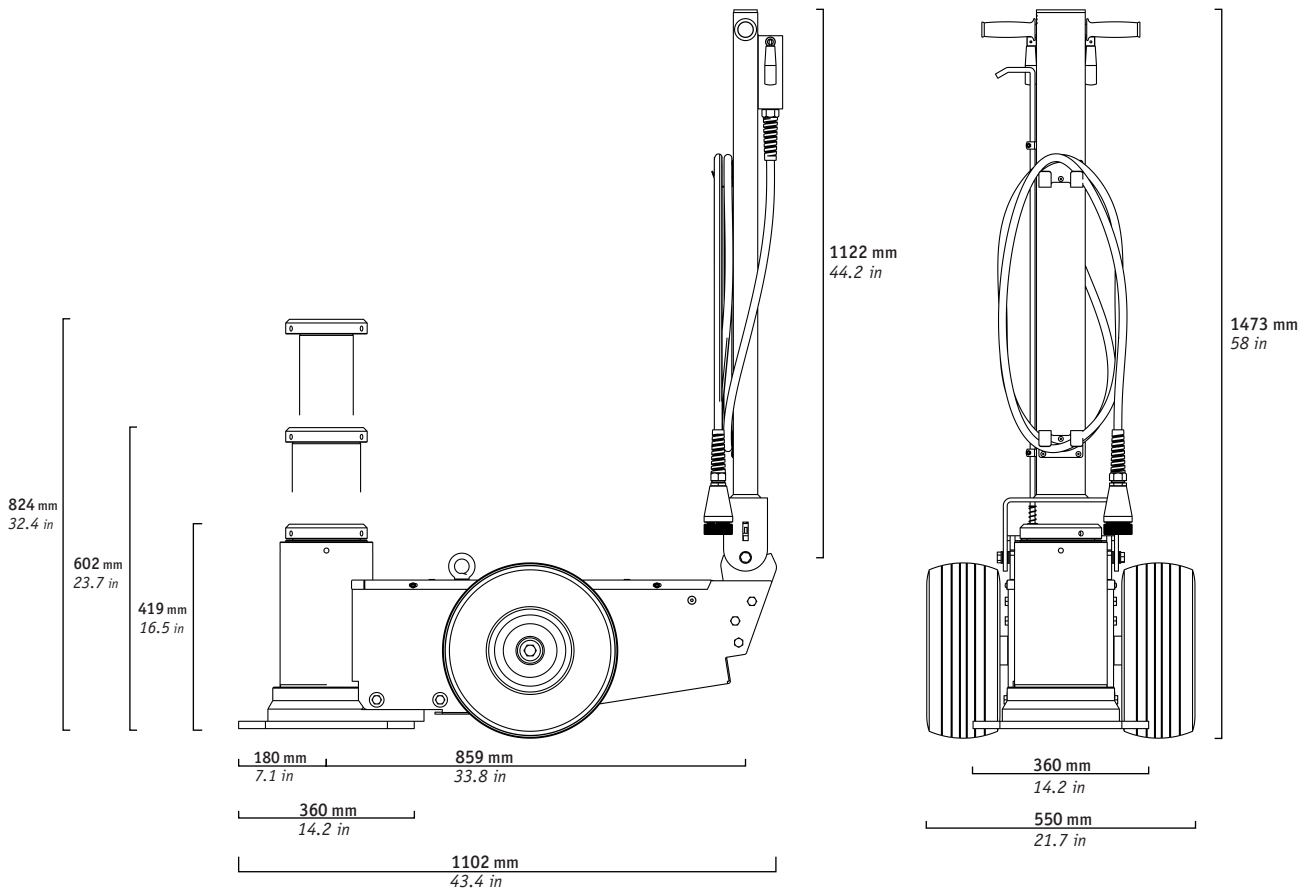

Accessories - Accessori

Code
Codice

Description
Descrizione

A00790	Safety Blocks Kit Kit Blocchi di Sicurezza
A06054	Extension Holder L Portaprolunghe SX
A06053	Extension Holder R Portaprolunghe DX
A04405	Extension Prolunga A: 80 mm B: 35 mm C: 20 mm D: 97 mm
A02432	Extension Prolunga A: 150 mm B: 35 mm C: 20 mm D: 97 mm
A02434	Extension Prolunga A: 250 mm B: 35 mm C: 20 mm D: 97 mm
A02436	Extension Prolunga A: 300 mm B: 35 mm C: 20 mm D: 97 mm
A08230	Extension with tilting plate Prolunga con piattello basculante A: 150 mm B: 35 mm C: 20 mm D: 97 mm
A08232	Extension with tilting plate Prolunga con piattello basculante A: 250 mm B: 35 mm C: 20 mm D: 97 mm
A08234	Extension with tilting plate Prolunga con piattello basculante A: 300 mm B: 35 mm C: 20 mm D: 97 mm
A04492	Tilting plate Piattello basculante A: 46 mm B: 35 mm C: 20 mm D: 97 mm



A00790



A06054



A06053



A04405



A02432



A02434



A02436



A08230



A08232



A08234



A04492

A00790 KIT:

- 1x Safety Blocks Holder - *Portablocchi*
- 1x Vertical Safety Blocks Holder - *Portablocchi verticale*
- 1x Eyebolt Extension - *Prolunga golfare*
- 4x Safety Block - *Blocco di sicurezza* - H100 - 177 mm
- 1x Safety Block - *Blocco di sicurezza* - H50 - 177 mm

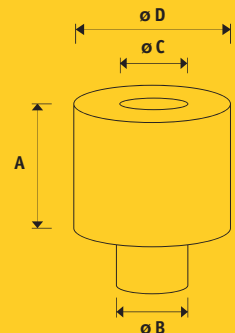



YouTube



Air-hydraulic jack engineered and manufactured to offer a solution that is safe and easy to use.

Main features:

- High Performance Motorpump (HPM)
- light, compact, easy to handle
- folding handle
- standard remote control
- standard air filter
- pneumatic tyres for any surface

Sollevatore oleopneumatico progettato e costruito per offrire una soluzione sicura e di facile utilizzo.

Caratteristiche principali:

- *motopompa ad alte prestazioni (HPM)*
- *estrema leggerezza, compattezza e maneggevolezza*
- *manico pieghevole*
- *comando remoto di serie*
- *filtro aria di serie*
- *ruote pneumatiche per ogni superficie*



M100-40

SUITABLE FOR
ADATTO A

Mine and oil field / Construction site
Industrial assembly / Agriculture / Railway applications / Military
Miniera e giacimento petrolifero / Cantiere
Assemblaggio industriale / Agricoltura / Applicazioni ferroviarie / Militare



NEW AIR FILTER
NUOVO FILTRO ARIA



	Capacity Portata	Net weight Peso netto	Working air press. Press. di alimentazione	Air consumption Consumo d'aria	Max. height Altezza max.	Min. height Altezza min.	Number of pistons Numero sfili	Stroke Corsa
M100-40	100 t 110.2 ton	179 kg 395 lb	10 - 12 bar 145 - 174 psi	600 NI/min	587 mm 23.1 in	399 mm 15.7 in	1	203 mm 8 in

Dimensions - Dimensionali

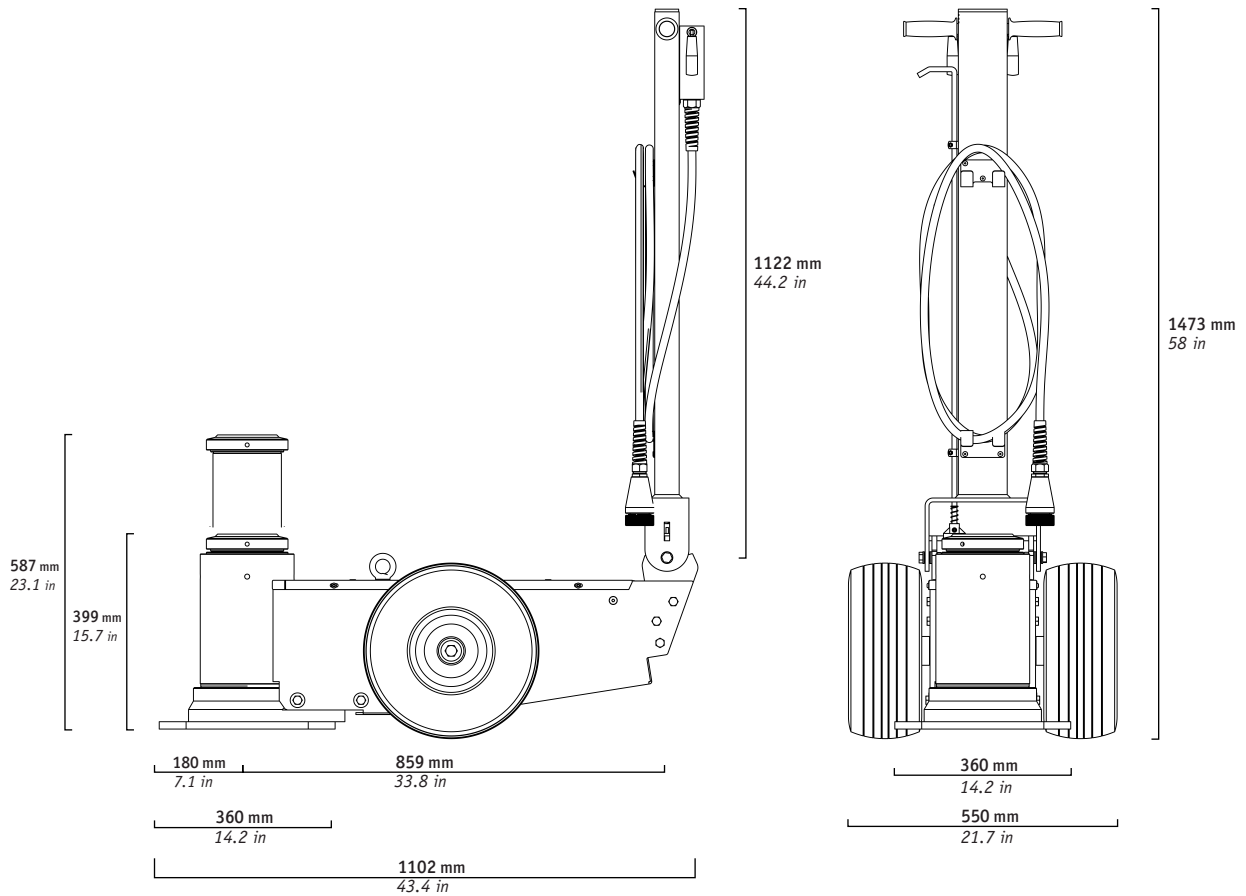

Accessories - Accessori

Code
Codice

Description
Descrizione

A05102	Safety Blocks Kit Kit Blocchi di Sicurezza
A06054	Extension Holder L Portaprolunghe SX
A06053	Extension Holder R Portaprolunghe DX
A04405	Extension Prolunga A: 80 mm B: 35 mm C: 20 mm D: 97 mm
A02432	Extension Prolunga A: 150 mm B: 35 mm C: 20 mm D: 97 mm
A02434	Extension Prolunga A: 250 mm B: 35 mm C: 20 mm D: 97 mm
A02436	Extension Prolunga A: 300 mm B: 35 mm C: 20 mm D: 97 mm
A08230	Extension with tilting plate Prolunga con piattello basculante A: 150 mm B: 35 mm C: 20 mm D: 97 mm
A08232	Extension with tilting plate Prolunga con piattello basculante A: 250 mm B: 35 mm C: 20 mm D: 97 mm
A08234	Extension with tilting plate Prolunga con piattello basculante A: 300 mm B: 35 mm C: 20 mm D: 97 mm
A04492	Tilting plate Piattello basculante A: 46 mm B: 35 mm C: 20 mm D: 97 mm



A05102 KIT:

- 1x Safety Blocks Holder - *Portablocchi*
- 1x Vertical Safety Blocks Holder - *Portablocchi verticale*
- 1x Eyebolt Extension - *Prolunga golfare*
- 4x Safety Block - *Blocco di sicurezza* - H100 - 177 mm
- 1x Safety Block - *Blocco di sicurezza* - H50 - 177 mm

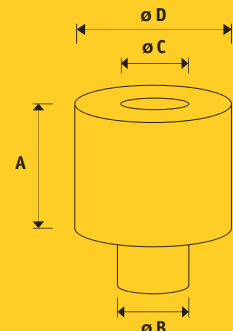



YouTube



Air-hydraulic jack engineered and manufactured to offer a solution that is safe and easy to use.

Main features:

- light, compact, easy to handle
- folding handle
- standard remote control
- standard air filter
- pneumatic tyres for any surface

Sollevatore oleopneumatico progettato e costruito per offrire una soluzione sicura e di facile utilizzo.

Caratteristiche principali:

- *estrema leggerezza, compattezza e maneggevolezza*
- *manico pieghevole*
- *comando remoto di serie*
- *filtro aria di serie*
- *ruote pneumatiche per ogni superficie*



M100-72

SUITABLE FOR
ADATTO A

Mine and oil field / Construction site
Industrial assembly / Agriculture / Railway applications / Military
*Miniera e giacimento petrolifero / Cantiere
Assemblaggio industriale / Agricoltura / Applicazioni ferroviarie / Militare*



**NEW AIR FILTER
NUOVO FILTRO ARIA**



	Capacity Portata	Net weight Peso netto	Working air press. Press. di alimentazione	Air consumption Consumo d'aria	Max. height Altezza max.	Min. height Altezza min.	Number of pistons Numero sfili	Stroke Corsa
M100-72	100 t 110.2 ton	289 kg 637 lb	10-12 bar 145-174 psi	600 NI/min	1170 mm 46.1 in	725 mm 28.5 in	1	445 mm 17.5 in

Dimensions - Dimensionali

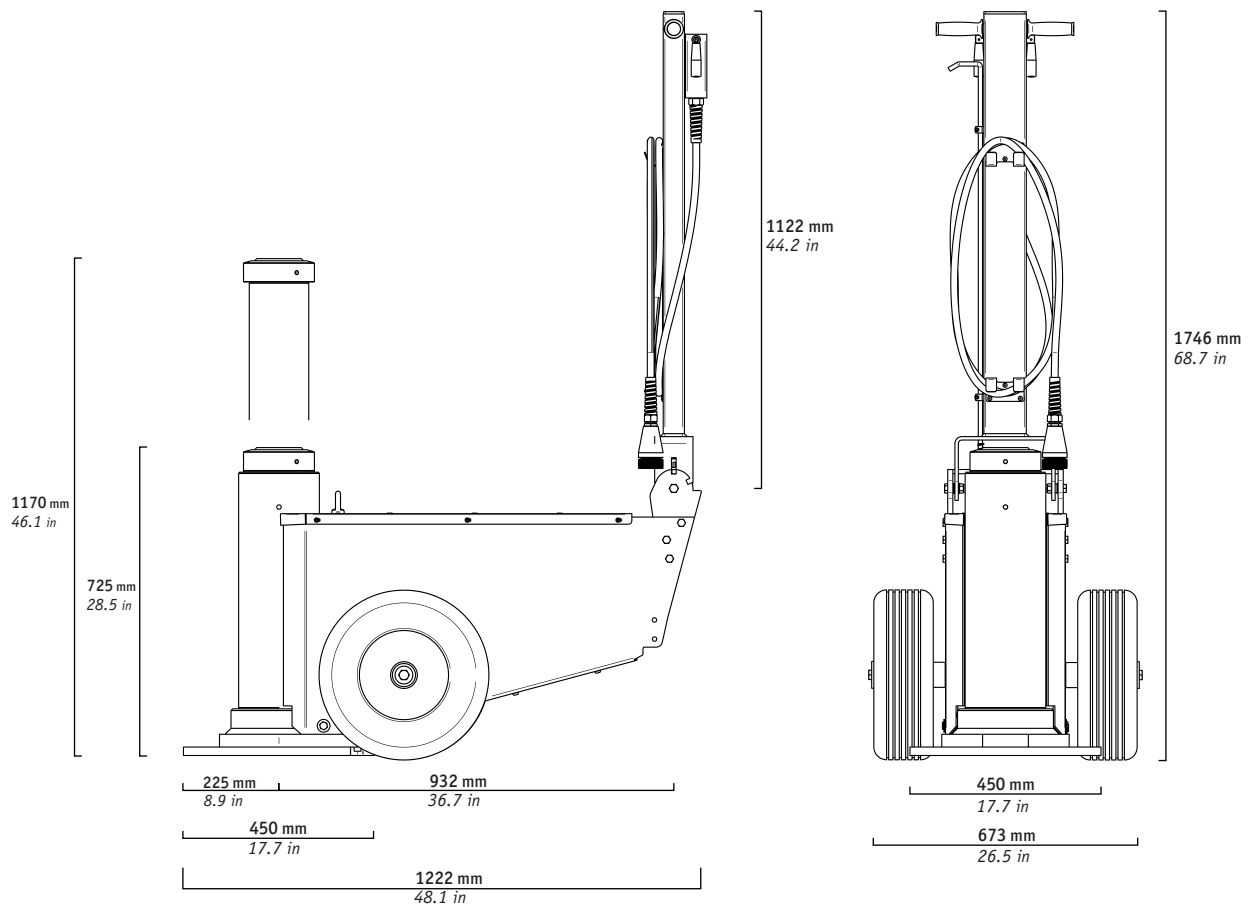

Accessories - Accessori

Code
Codice

Description
Descrizione

A00788 Safety Blocks Kit
Kit Blocchi di Sicurezza

A06052 Extension Holder L
Portaprolunghe SX

A06051 Extension Holder R
Portaprolunghe DX

A02421 Extension
Prolunga
A: 200 mm B: 55 mm
C: 55 mm D: 138 mm

A02422 Extension
Prolunga
A: 250 mm B: 55 mm
C: 55 mm D: 138 mm

A02423 Extension
Prolunga
A: 300 mm B: 55 mm
C: 55 mm D: 138 mm

A04495 Tilting plate
Piatello basculante
A: 77 mm B: 55 mm D: 138 mm



A00788 KIT:

- 1x Safety Blocks Holder - *Portablocchi*
- 1x Eyebolt Extension - *Prolunga golfare*
- 4x Safety Block - *Blocco di sicurezza* - H100 - 177 mm
- 1x Safety Block - *Blocco di sicurezza* - H50 - 177 mm

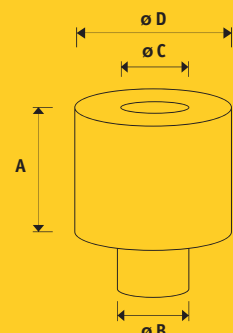



YouTube



Air-hydraulic jack engineered and manufactured to offer a solution that is safe and easy to use.

Main features:

- light, compact, easy to handle
- folding handle
- standard remote control
- standard air filter
- pneumatic tyres for any surface

Sollevatore oleopneumatico progettato e costruito per offrire una soluzione sicura e di facile utilizzo.

Caratteristiche principali:

- *estrema leggerezza, compattezza e maneggevolezza*
- *manico pieghevole*
- *comando remoto di serie*
- *filtro aria di serie*
- *ruote pneumatiche per ogni superficie*



M100-90

SUITABLE FOR
ADATTO A

Mine and oil field / Construction site
Industrial assembly / Agriculture / Railway applications / Military
*Miniera e giacimento petrolifero / Cantiere
Assemblaggio industriale / Agricoltura / Applicazioni ferroviarie / Militare*



NEW AIR FILTER
NUOVO FILTRO ARIA

	Capacity Portata	Net weight Peso netto	Working air press. Press. di alimentazione	Air consumption Consumo d'aria	Max. height Altezza max.	Min. height Altezza min.	Number of pistons Numero sfili	Stroke Corsa
M100-90	100 t 110.2 ton	294 kg 648 lb	10-12 bar 145-174 psi	600 NI/min	1466 mm 57.7 in	900 mm 35.4 in	1	566 mm 22.3 in

Dimensions - Dimensionali

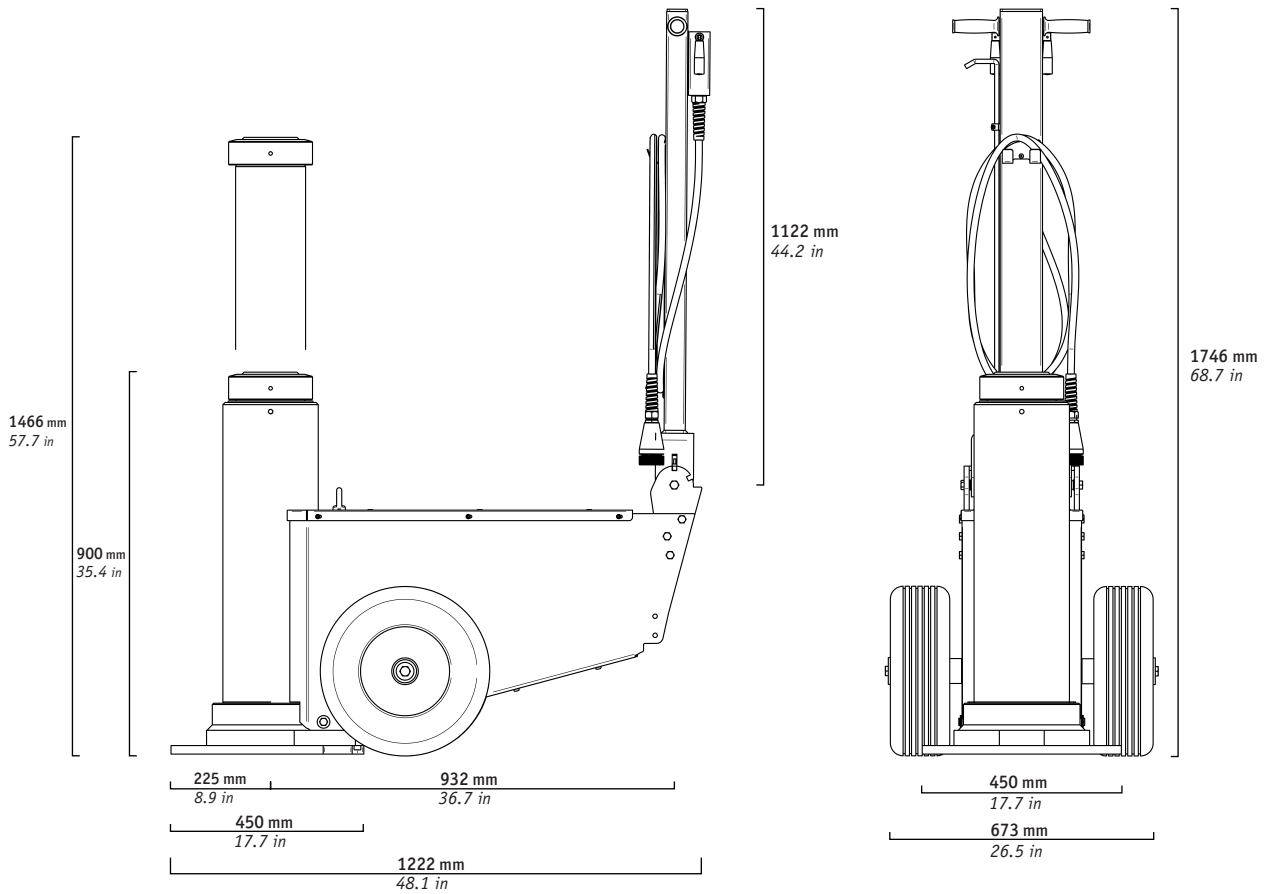

Accessories - Accessori

Code
Codice

Description
Descrizione

A07350 Safety Blocks Kit
Kit Blocchi di Sicurezza

A06052 Extension Holder L
Portaprolunghe SX

A06051 Extension Holder R
Portaprolunghe DX

A02421 Extension
Prolunga
A: 200 mm B: 55 mm
C: 55 mm D: 138 mm

A02422 Extension
Prolunga
A: 250 mm B: 55 mm
C: 55 mm D: 138 mm

A02423 Extension
Prolunga
A: 300 mm B: 55 mm
C: 55 mm D: 138 mm

A04495 Tilting plate
Pialettino basculante
A: 77 mm B: 55 mm D: 138 mm



A07350



A06052



A06051



A02421



A02422



A02423



A04495

A07350 KIT:

1x Safety Blocks Holder - *Portablocchi*
4x Safety Block - *Blocco di sicurezza* - H100 - 177 mm
1x Safety Block - *Blocco di sicurezza* - H50 - 177 mm

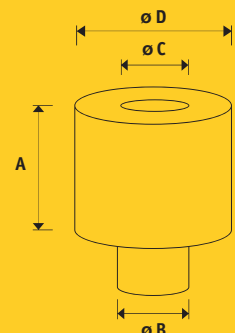



Air-hydraulic jack engineered and manufactured to offer a solution that is safe and easy to use.

Main features:

- light, compact, easy to handle
- folding handle
- standard remote control
- standard air filter
- pneumatic tyres for any surface

Sollevatore oleopneumatico progettato e costruito per offrire una soluzione sicura e di facile utilizzo.

Caratteristiche principali:

- *estrema leggerezza, compattezza e maneggevolezza*
- *manico pieghevole*
- *comando remoto di serie*
- *filtro aria di serie*
- *ruote pneumatiche per ogni superficie*



M150-72

**SUITABLE FOR
ADATTO A**

Mine and oil field / Construction site
Industrial assembly / Agriculture / Railway applications / Military
*Miniera e giacimento petrolifero / Cantiere
Assemblaggio industriale / Agricoltura / Applicazioni ferroviarie / Militare*



**NEW AIR FILTER
NUOVO FILTRO ARIA**



	Capacity Portata	Net weight Peso netto	Working air press. Press. di alimentazione	Air consumption Consumo d'aria	Max. height Altezza max.	Min. height Altezza min.	Number of pistons Numero sfili	Stroke Corsa
M150-72	150 t 165.3 ton	367 kg 809 lb	10-12 bar 145-174 psi	600 NI/min	1254 mm 49.4 in	720 mm 28.3 in	1	372 mm 14.6 in

Dimensions - Dimensionali

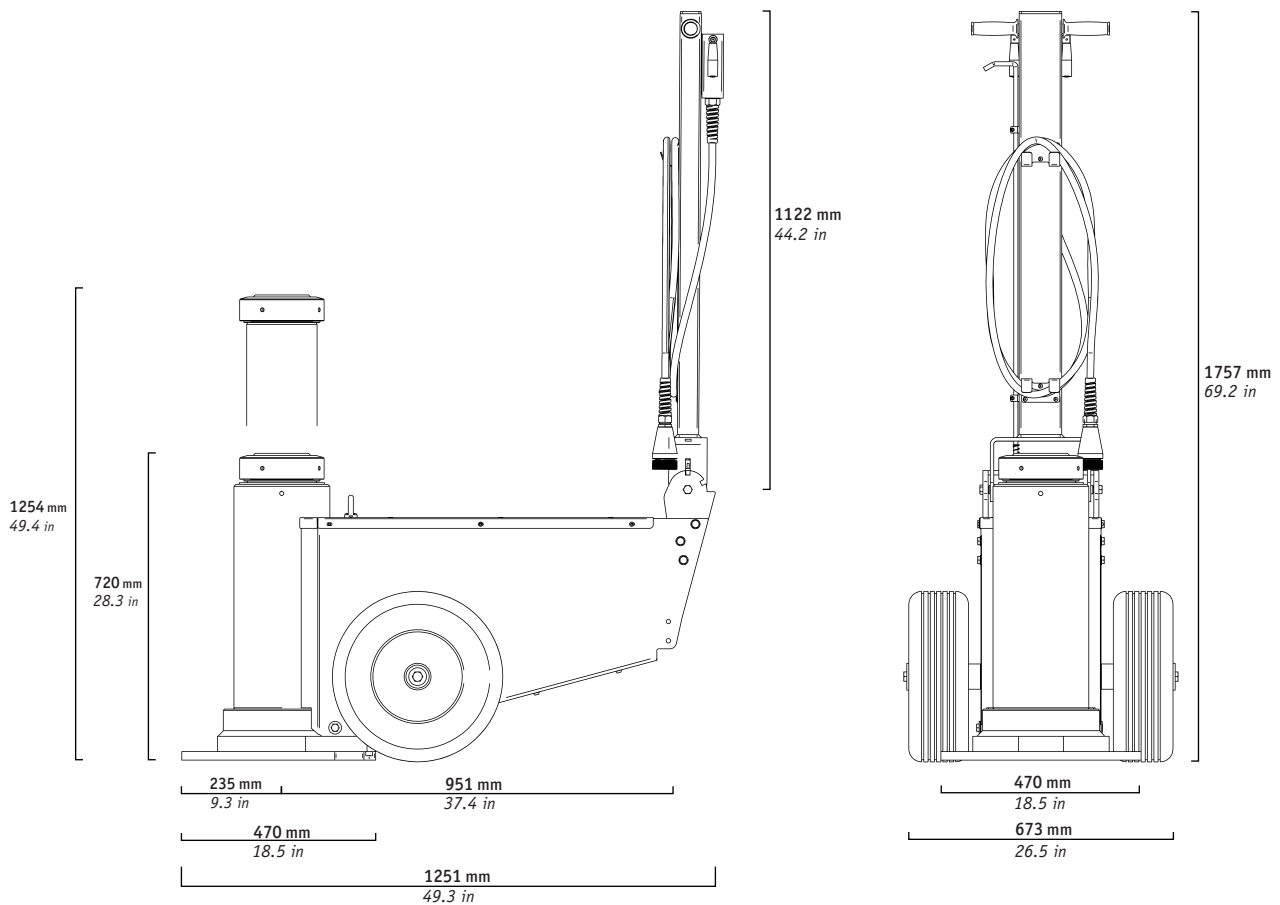

Accessories - Accessori

Code
Codice

Description
Descrizione

A07351 Safety Blocks Kit
Kit Blocchi di Sicurezza

A06052 Extension Holder L
Portaprolunghe SX

A06051 Extension Holder R
Portaprolunghe DX

A02421 Extension
Prolunga
A: 200 mm B: 55 mm
C: 55 mm D: 138 mm

A02422 Extension
Prolunga
A: 250 mm B: 55 mm
C: 55 mm D: 138 mm

A02423 Extension
Prolunga
A: 300 mm B: 55 mm
C: 55 mm D: 138 mm

A04495 Tilting plate
Piastrino basculante
A: 77 mm B: 55 mm D: 138 mm

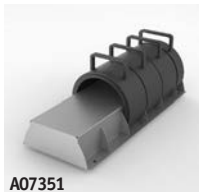

A07351



A06052



A06051



A02421



A02422



A02423



A04495

A07351 KIT:

1x Safety Blocks Holder - *Portablocchi*
3x Safety Block - *Blocco di sicurezza* - H100 - 177 mm
1x Safety Block - *Blocco di sicurezza* - H50 - 177 mm

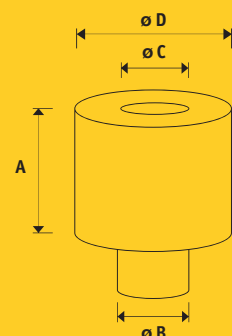



YouTube



Air-hydraulic jack engineered and manufactured to offer a solution that is safe and easy to use.

Main features:

- light, compact, easy to handle
- folding handle
- standard remote control
- standard air filter
- pneumatic tyres for any surface

Sollevatore oleopneumatico progettato e costruito per offrire una soluzione sicura e di facile utilizzo.

Caratteristiche principali:

- *estrema leggerezza, compattezza e maneggevolezza*
- *manico pieghevole*
- *comando remoto di serie*
- *filtro aria di serie*
- *ruote pneumatiche per ogni superficie*



M150-90

SUITABLE FOR
ADATTO A

Mine and oil field / Construction site
Industrial assembly / Agriculture / Railway applications / Military
*Miniera e giacimento petrolifero / Cantiere
Assemblaggio industriale / Agricoltura / Applicazioni ferroviarie / Militare*



NEW AIR FILTER
NUOVO FILTRO ARIA



	Capacity Portata	Net weight Peso netto	Working air press. Press. di alimentazione	Air consumption Consumo d'aria	Max. height Altezza max.	Min. height Altezza min.	Number of pistons Numero sfili	Stroke Corsa
M150-90	150 t 165.3 ton	377 kg 831 lb	10-12 bar 145-174 psi	600 NI/min	1435 mm 56.5 in	901 mm 35.5 in	1	554 mm 21.8 in

Dimensions - Dimensionali

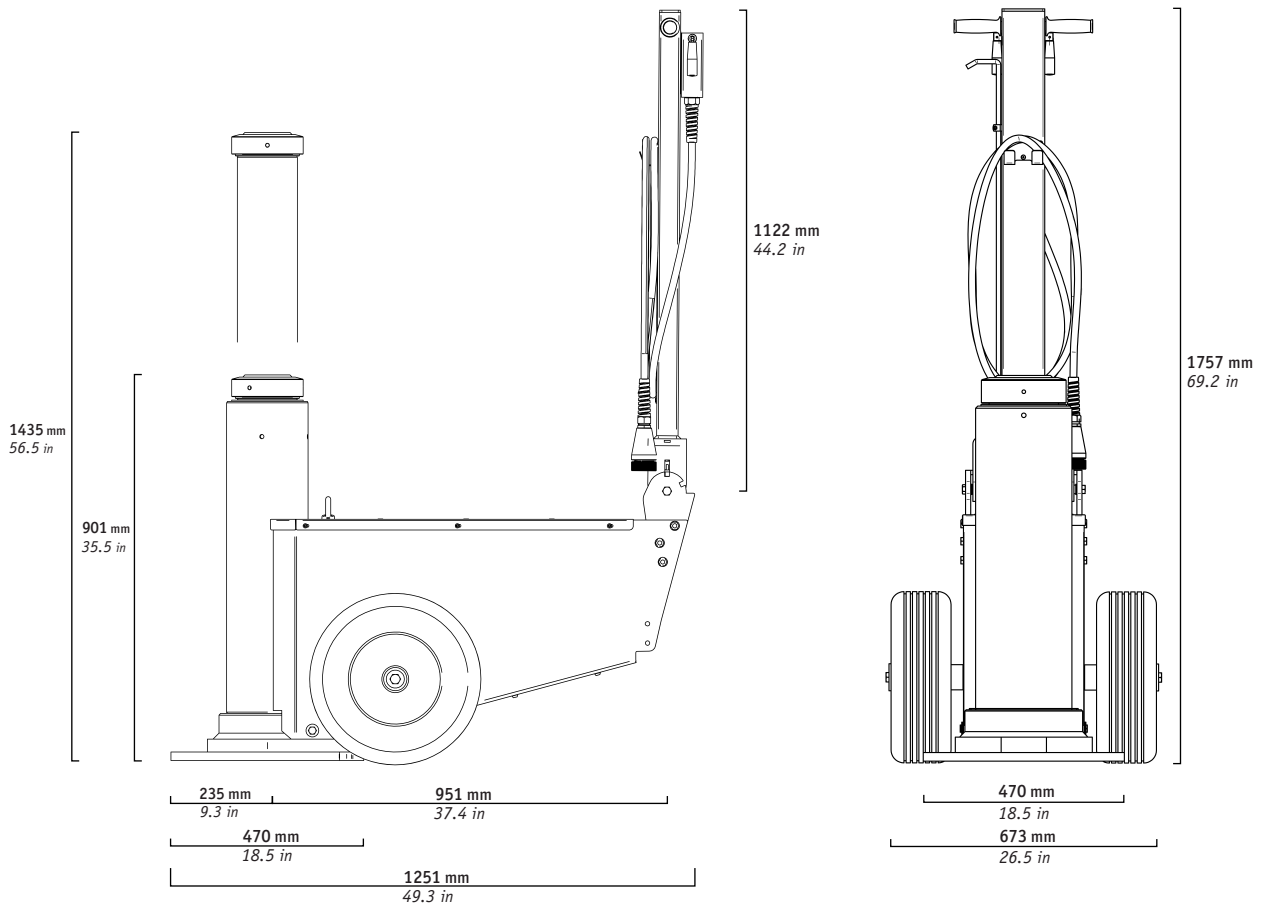

Accessories - Accessori

Code
Codice

Description
Descrizione

A00789 Safety Blocks Kit
Kit Blocchi di Sicurezza

A06052 Extension Holder L
Portaprolunghe SX

A06051 Extension Holder R
Portaprolunghe DX

A02421 Extension
Prolunga
A: 200 mm B: 55 mm
C: 55 mm D: 138 mm

A02422 Extension
Prolunga
A: 250 mm B: 55 mm
C: 55 mm D: 138 mm

A02423 Extension
Prolunga
A: 300 mm B: 55 mm
C: 55 mm D: 138 mm

A04495 Tilting plate
Piatello basculante
A: 77 mm B: 55 mm D: 138 mm



A00789



A06052



A06051



A02421



A02422



A02423



A04495

A00789 KIT:

1x Safety Blocks Holder - *Portablocchi*
5x Safety Block - *Blocco di sicurezza* - H100 - 216 mm
1x Safety Block - *Blocco di sicurezza* - H50 - 216 mm

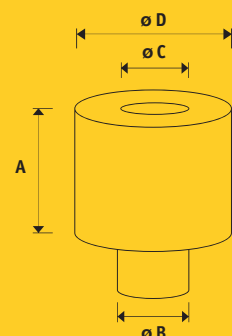



Air-hydraulic jack engineered and manufactured to offer a solution that is safe and easy to use.

Main features:

- light, compact, easy to handle
- folding handle
- standard remote control
- standard air filter
- pneumatic tyres for any surface

Sollevatore oleopneumatico progettato e costruito per offrire una soluzione sicura e di facile utilizzo.

Caratteristiche principali:

- *estrema leggerezza, compattezza e maneggevolezza*
- *manico pieghevole*
- *comando remoto di serie*
- *filtro aria di serie*
- *ruote pneumatiche per ogni superficie*



M200-65

**SUITABLE FOR
ADATTO A**

Mine and oil field / Construction site
Industrial assembly / Agriculture / Railway applications / Military
*Miniera e giacimento petrolifero / Cantiere
Assemblaggio industriale / Agricoltura / Applicazioni ferroviarie / Militare*



**NEW AIR FILTER
NUOVO FILTRO ARIA**

	Capacity Portata	Net weight Peso netto	Working air press. Press. di alimentazione	Air consumption Consumo d'aria	Max. height Altezza max.	Min. height Altezza min.	Number of pistons Numero sfili	Stroke Corsa
M200-65	200 t 220.4 ton	358 kg 789 lb	10-12 bar 145-174 psi	600 NI/min	1000 mm 39.4 in	650 mm 25.6 in	1	350 mm 13.8 in

Dimensions - Dimensionali

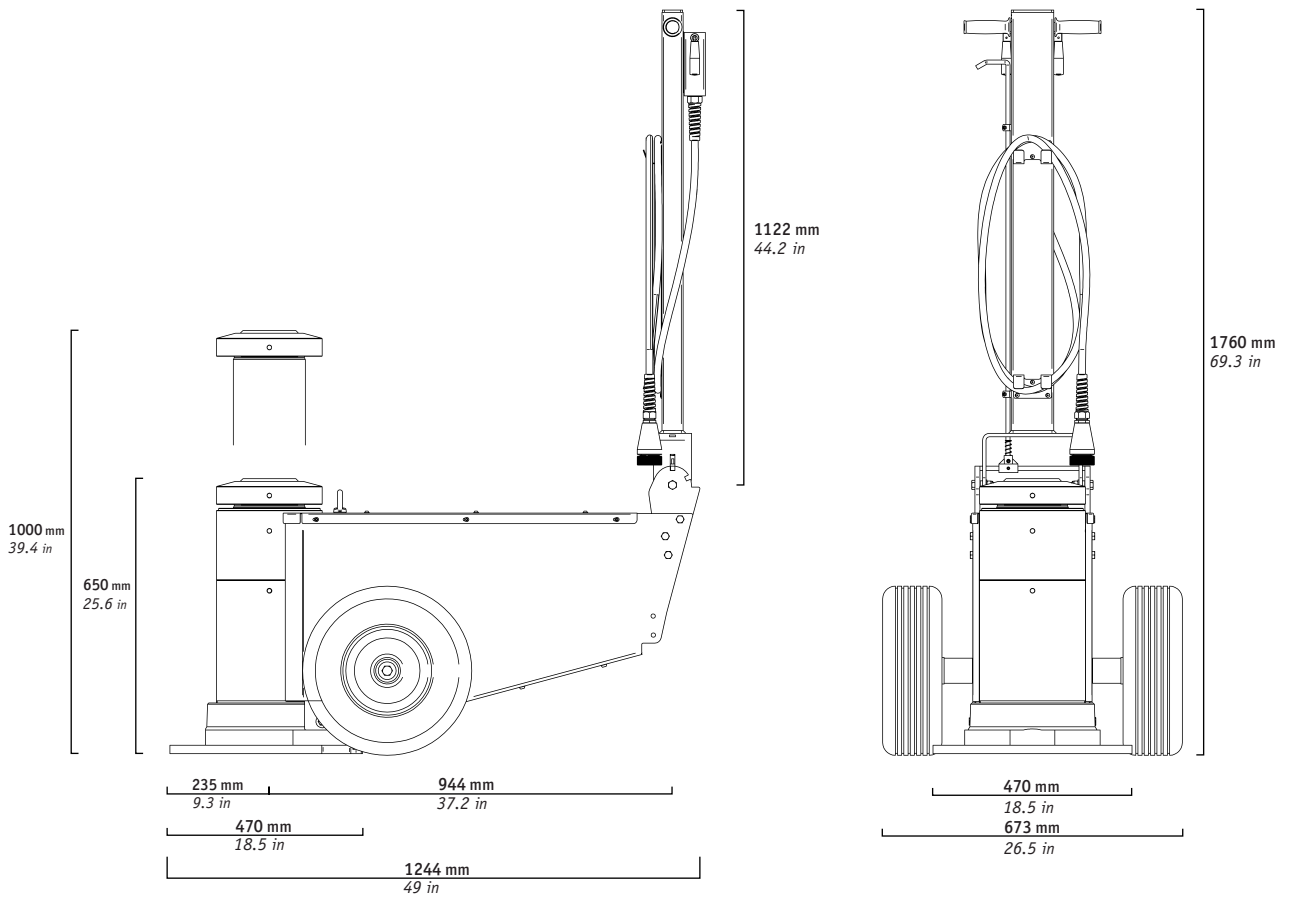

Accessories - Accessori

Code
Codice

Description
Descrizione

A07325	Safety Blocks Kit Kit Blocchi di Sicurezza
A06052	Extension Holder L Portaprolunghe SX
A06051	Extension Holder R Portaprolunghe DX
A02421	Extension Prolunga A: 200 mm B: 55 mm C: 55 mm D: 138 mm
A02422	Extension Prolunga A: 250 mm B: 55 mm C: 55 mm D: 138 mm
A02423	Extension Prolunga A: 300 mm B: 55 mm C: 55 mm D: 138 mm
A04495	Tilting plate Piatello basculante A: 77 mm B: 55 mm D: 138 mm



A07325



A06052



A06051



A02421



A02422



A02423



A04495

A07325 KIT:

- 1x Safety Blocks Holder - *Portablocchi*
- 4x Safety Block - *Blocco di sicurezza* - H100 - 250 mm
- 1x Safety Block - *Blocco di sicurezza* - H50 - 250 mm

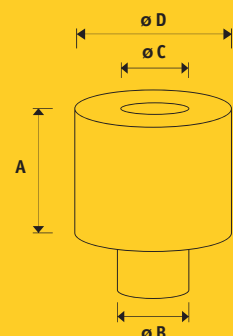



Air-hydraulic jack engineered and manufactured to offer a solution that is safe and easy to use.

Main features:

- light, compact, easy to handle
- folding handle
- standard remote control
- standard air filter
- pneumatic tyres for any surface

Sollevatore oleopneumatico progettato e costruito per offrire una soluzione sicura e di facile utilizzo.

Caratteristiche principali:

- *estrema leggerezza, compattezza e maneggevolezza*
- *manico pieghevole*
- *comando remoto di serie*
- *filtro aria di serie*
- *ruote pneumatiche per ogni superficie*



M200-90

SUITABLE FOR
ADATTO A

Mine and oil field / Construction site
Industrial assembly / Agriculture / Railway applications / Military
*Miniera e giacimento petrolifero / Cantiere
Assemblaggio industriale / Agricoltura / Applicazioni ferroviarie / Militare*



NEW AIR FILTER
NUOVO FILTRO ARIA



	Capacity Portata	Net weight Peso netto	Working air press. Press. di alimentazione	Air consumption Consumo d'aria	Max. height Altezza max.	Min. height Altezza min.	Number of pistons Numero sfili	Stroke Corsa
M200-90	200 t 220.4 ton	462 kg 1018 lb	10-12 bar 145-174 psi	600 NI/min	1450 mm 57.1 in	900 mm 35.4 in	1	550 mm 21.7 in

Dimensions - Dimensionali

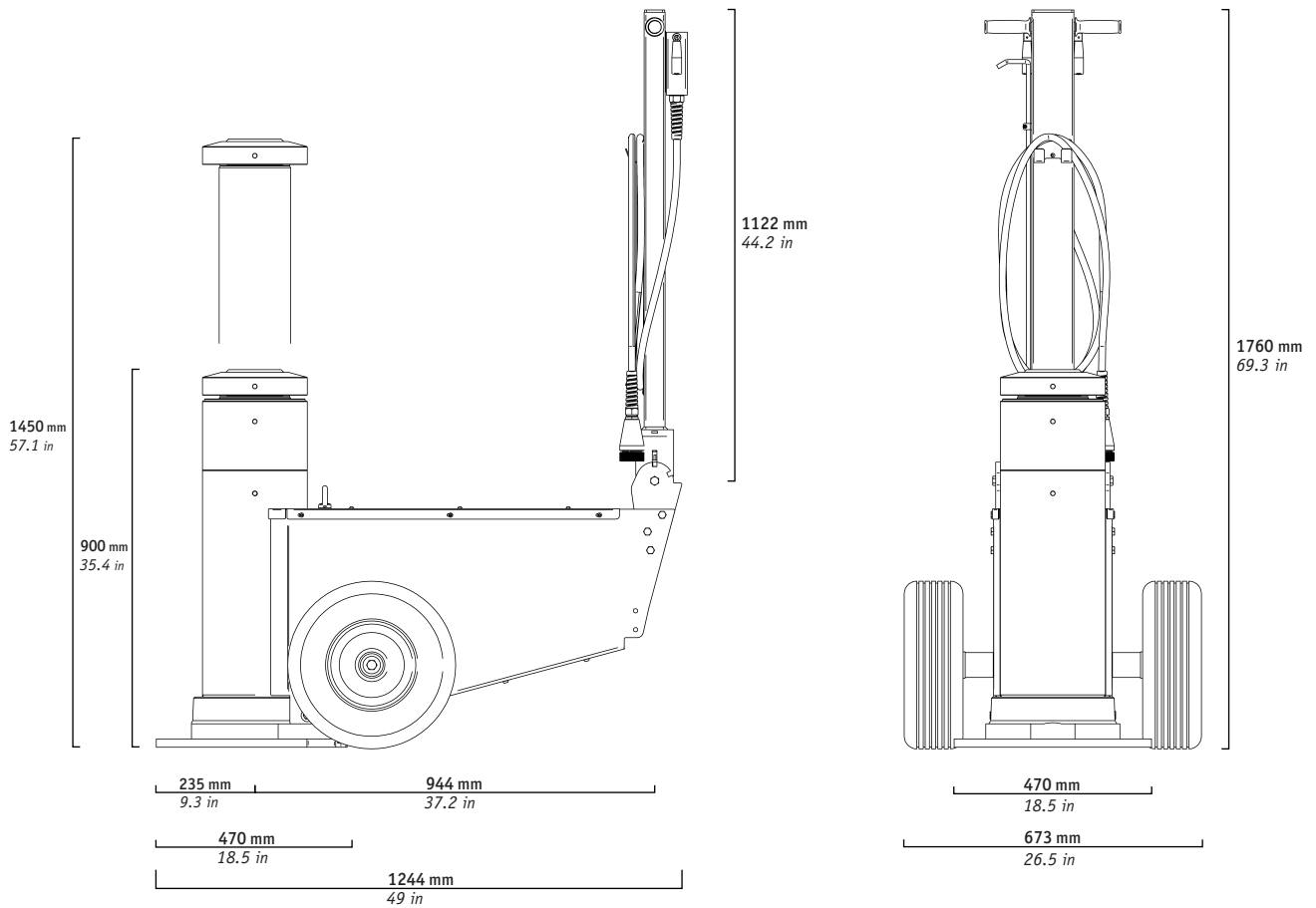

Accessories - Accessori

Code
Codice

Description
Descrizione

A07326 Safety Blocks Kit
Kit Blocchi di Sicurezza

A06052 Extension Holder L
Portaprolunghe SX

A06051 Extension Holder R
Portaprolunghe DX

A02421 Extension
Prolunga
A: 200 mm B: 55 mm
C: 55 mm D: 138 mm

A02422 Extension
Prolunga
A: 250 mm B: 55 mm
C: 55 mm D: 138 mm

A02423 Extension
Prolunga
A: 300 mm B: 55 mm
C: 55 mm D: 138 mm

A04495 Tilting plate
Piatello basculante
A: 77 mm B: 55 mm D: 138 mm



A07326 KIT:

1x Safety Blocks Holder - *Portablocchi*
5x Safety Block - *Blocco di sicurezza* - H100 - 250 mm
1x Safety Block - *Blocco di sicurezza* - H50 - 250 mm

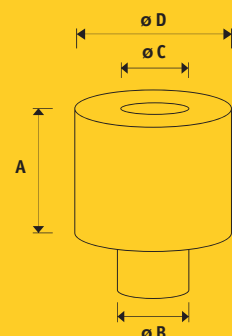

A close-up, low-angle shot of the undercarriage of a large tracked vehicle, likely a bulldozer or excavator. The image shows the heavy-duty metal components of the axle stand, including the track roller and the suspension arms. The ground is composed of loose soil and gravel. The text "AXLE STANDS" is overlaid in white, bold, sans-serif font in the upper left quadrant. Below it, the Italian text "COLONNETTE DI SOSTEGNO" is also overlaid in the same style. The track itself is visible at the bottom, showing its tread pattern and some embossed markings like "XDR3" and "EHR".

AXLE STANDS

**COLONNETTE DI
SOSTEGNO**



MAMMUT



This MAMMUT axle stand is perfect to sustain up to 40 metric tons (AS-NZ standard compliant up to 20 t) after the lifting operation. It allows to work safely and efficiently. The jack stand can be easily adjusted without air or electric power in six height positions.

Colonna di sostegno linea MAMMUT progettata per sostenere al meglio fino a 40 tonnellate di carico dopo il sollevamento (portata di 20 t nella versione AS-NZ). Facilmente regolabile in sei posizioni, non richiede collegamento elettrico o all'aria compressa.

MXM

SUITABLE FOR
ADATTO A

Mine and oil field / Construction site
Industrial assembly / Agriculture / Railway applications / Military
Miniera e giacimento petrolifero / Cantiere
Assemblaggio industriale / Agricoltura / Applicazioni ferroviarie / Militare



Code
Codice

Capacity
Portata

Weight
Peso

Min. height
Altezza min.

Max. height
Altezza max.

Positions
Posizioni

MXM 20-120-ASNZ

20 t

61 kg

700 mm

1200 mm

6

22 ton

134 lb

27.6 in

47.2 in

MXM 40-120

40 t

61 kg

700 mm

1200 mm

6

44 ton

134 lb

27.6 in

47.2 in

Dimensions - Dimensionali

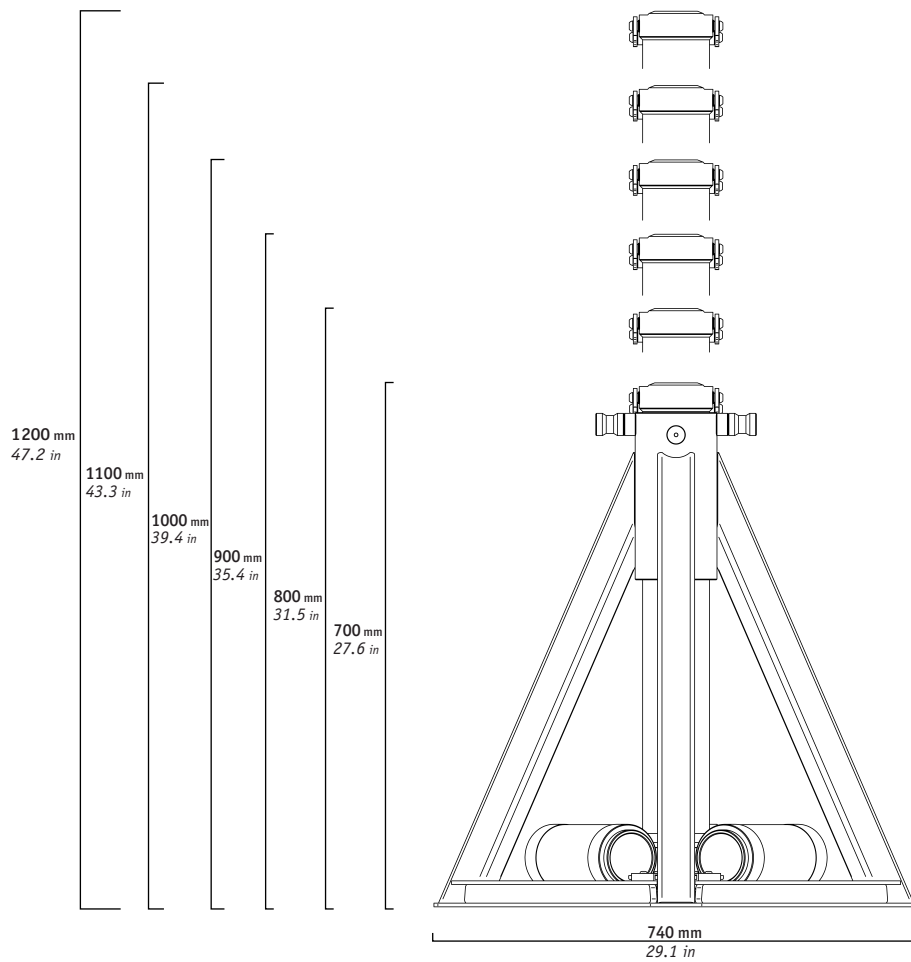

Accessories - Accessori

Code
Codice

Description
Descrizione

A08879

Moving trolley
Carrello di spostamento

22 kg - 48 lb



To make it even easier to move our jack stand, we created an extremely light and compact trolley. Its design makes it suitable for working in any condition, even the most extreme. Fully foldable.

Per rendere ancora più facile lo spostamento della colonnetta abbiamo creato un carrello estremamente leggero e compatto. Progettato per lavorare in ogni condizione, anche le più estreme. Completamente ripieghevole.

A08879



YouTube



This MAMMUT axle stand is perfect to sustain up to 150 metric tons (AS-NZ standard compliant up to 100 t) after the lifting operation. The pneumatic adjustment of the jack stand height is fast and extremely efficient. Compressed air (4-12 bar range) is required.

Colonna di sostegno linea MAMMUT progettata per sostenere al meglio fino a 150 tonnellate di carico dopo il sollevamento (portata di 100 t nella versione AS-NZ). Regolazione pneumatica dell'altezza veloce ed efficiente. Richiede il collegamento all'aria compressa (4 -12 bar).



MXA

SUITABLE FOR
ADATTO A

Mine and oil field / Construction site
Industrial assembly / Agriculture / Railway applications / Military
Miniera e giacimento petrolifero / Cantiere
Assemblaggio industriale / Agricoltura / Applicazioni ferroviarie / Militare



Code Codice	Capacity Portata	Weight Peso	Min. height Altezza min.	Max. height Altezza max.	Positions Posizioni	Air requirement Pressione aria
MXA 50-100-ASNZ	50 t 55.1 ton	110 kg 242 lb	600 mm 23.6 in	1000 mm 39.4 in	5	4-12 bar 58-174 psi
MXA 75-100	75 t 82 ton	110 kg 242 lb	600 mm 23.6 in	1000 mm 39.4 in	5	4-12 bar 58-174 psi
MXA 100-115-ASNZ	100 t 110 ton	160 kg 359 lb	700 mm 27.6 in	1150 mm 45.3 in	5	4-12 bar 58-174 psi
MXA 150-115	150 t 165 ton	160 kg 359 lb	700 mm 27.6 in	1150 mm 45.3 in	5	4-12 bar 58-174 psi

Dimensions - Dimensionali

MXA 50-100-ASNZ
MXA 75-100

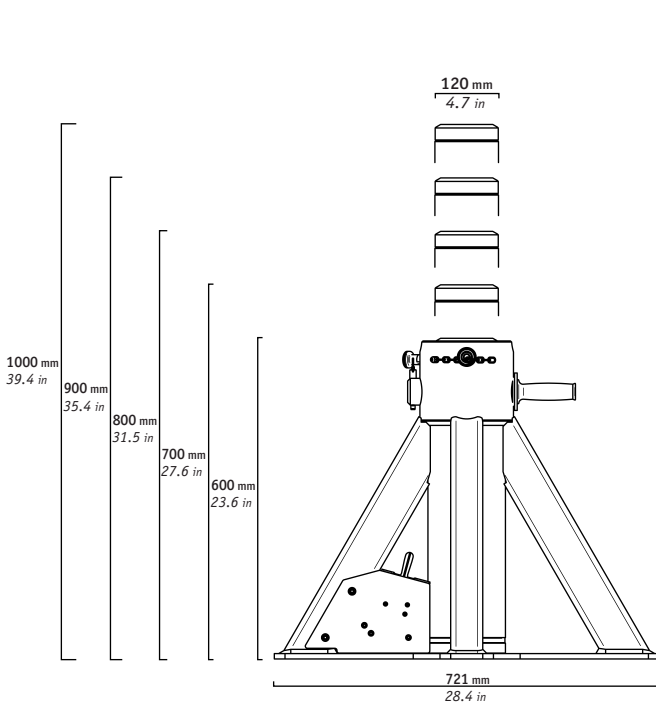

MXA 100-115-ASNZ
MXA 150-115

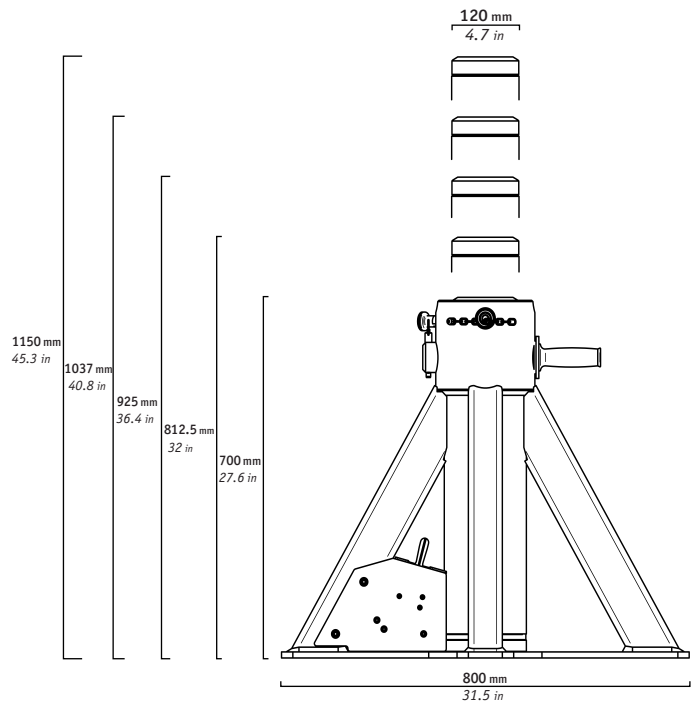

Accessories - Accessori

Code
Codice

Description
Descrizione

A04405	Extension Prolunga A: 80 mm B: 35 mm C: 20 mm D: 97 mm
A02432	Extension Prolunga A: 150 mm B: 35 mm C: 20 mm D: 97 mm
A02434	Extension Prolunga A: 250 mm B: 35 mm C: 20 mm D: 97 mm
A02436	Extension Prolunga A: 300 mm B: 35 mm C: 20 mm D: 97 mm
A08230	Extension with tilting plate Prolunga con piattello basculante A: 150 mm B: 35 mm C: 20 mm D: 97 mm
A08232	Extension with tilting plate Prolunga con piattello basculante A: 250 mm B: 35 mm C: 20 mm D: 97 mm
A08234	Extension with tilting plate Prolunga con piattello basculante A: 300 mm B: 35 mm C: 20 mm D: 97 mm
A04492	Tilting plate Piattello basculante A: 46 mm B: 35 mm C: 20 mm D: 97 mm
A08879	Moving trolley Carrello di spostamento 22 kg - 48 lb

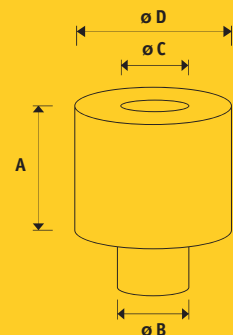



ATLAS

AIR-HYDRAULIC JACK WITH INTEGRATED SAFE LOAD SYSTEM



ATLAS



Created from an innovative engineering study, the ATLAS air-hydraulic jack represents the technological vanguard of the MAMMUT range by CATTINI OLEOPNEUMATICA.

Thanks to the mechanical patented locking system, operated by a remote control, ATLAS makes it possible to work safely under the lifted vehicle, without the use of jack stands or support blocks.

When the locking system, located in the cylinder unit, comes into operation and blocks the load, a green LED lights up automatically.

Starting from this point, the operator can easily carry out the maintenance on the vehicle in an efficient and safe way.

Nato da un innovativo studio ingegneristico, il sollevatore oleopneumatico ATLAS, rappresenta l'avanguardia tecnologica della gamma MAMMUT firmata CATTINI OLEOPNEUMATICA.

Grazie, infatti, al sistema meccanico di bloccaggio brevettato interno al cilindro, azionabile da comando remoto, ATLAS permette di lavorare in sicurezza sotto al veicolo sollevato, senza l'impiego di colonnette o l'ausilio di blocchi di sostegno. Quando il sistema entra in funzione, bloccando il carico, un indicatore visivo verde si accende automaticamente, garantendo all'operatore la possibilità di eseguire la manutenzione del mezzo, in modo semplice, efficiente e sicuro.





ATLAS



YouTube



Air-hydraulic jack with integrated safe load system.

Main features:

- Mechanical safety lock sealed inside the cylinder unit to protect it from dirt and dust
- Standard remote control for all functions
- "Safe Load" LED indicators
- Standard air filter
- Lightweight, compact, easy to handle and safe to use
- Folding handle
- Pneumatic tyres for any surface

Sollevatore oleopneumatico con sistema di bloccaggio integrato.

Caratteristiche principali:

- *Blocco meccanico di sicurezza sigillato all'interno del cilindro per proteggerlo da sporco e polvere*
- *Comando remoto di serie per lo svolgimento di tutte le funzioni*
- *Indicatori LED dello stato di sicurezza del carico*
- *Filtro aria di serie*
- *Leggero, compatto, maneggevole e sicuro*
- *Manico pieghevole*
- *Ruote pneumatiche per ogni superficie*



M100-72-ATLAS

SUITABLE FOR
ADATTO A

Mine and oil field / Construction site
Industrial assembly / Agriculture / Railway applications / Military
Miniera e giacimento petrolifero / Cantiere
Assemblaggio industriale / Agricoltura / Applicazioni ferroviarie / Militare



	Capacity Portata	Net weight Peso netto	Working air press. Press. di alimentazione	Air consumption Consumo d'aria	Max. height Altezza max.	Min. height Altezza min.	Number of pistons Numero sfili	Stroke Corsa
M100-72-ATLAS	100 t 110.2 ton	450 kg 992 lb	10-12 bar 145-174 psi	600 NI/min	1062 mm 41.8 in	722 mm 28.4 in	1	340 mm 13.4 in

Dimensions - Dimensionali

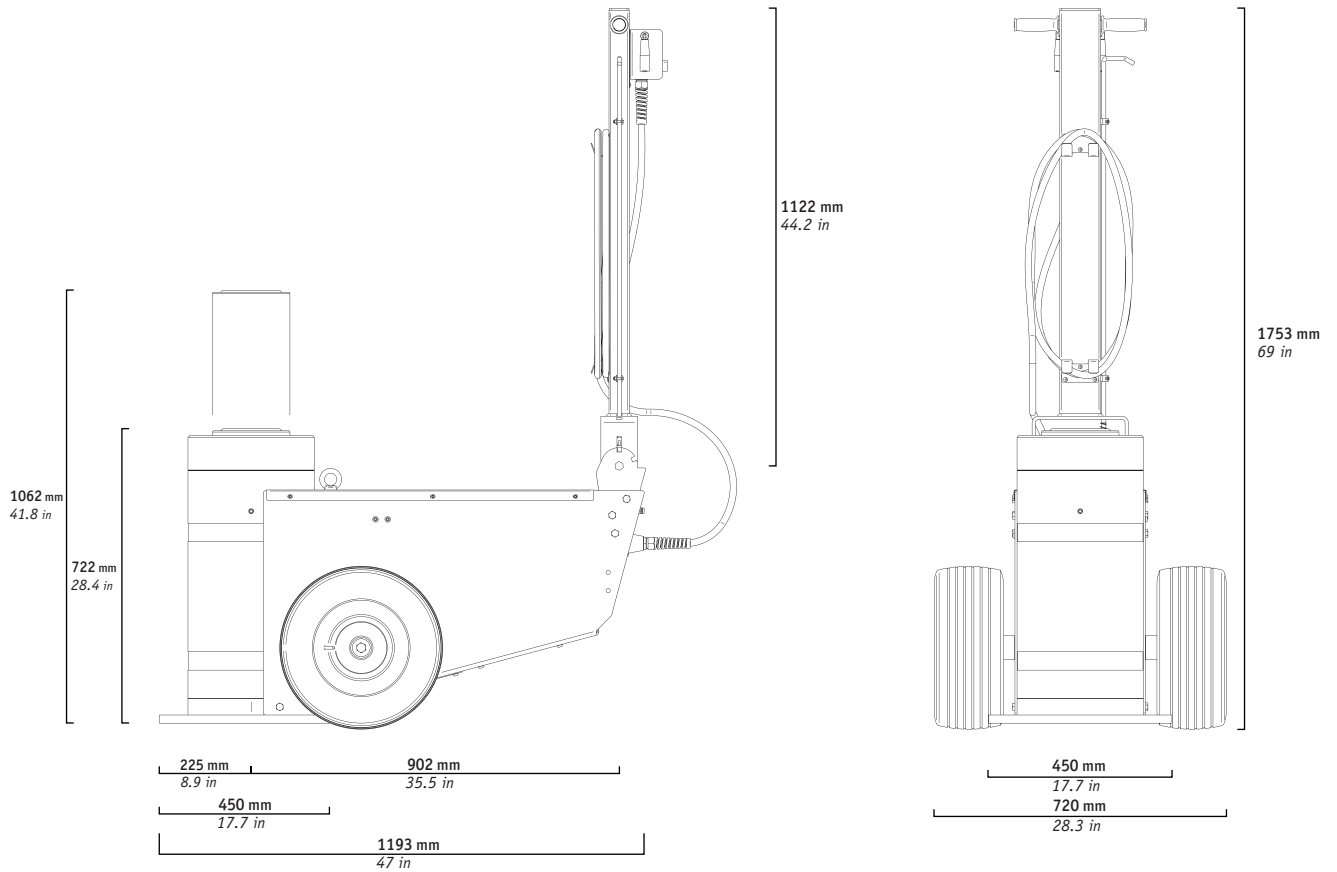

Accessories - Accessori

Code
Codice

Description
Descrizione

A06052	Extension Holder L Portaprolunghe SX
A06051	Extension Holder R Portaprolunghe DX
A02421	Extension Prolunga A: 200 mm B: 55 mm C: 55 mm D: 138 mm
A02422	Extension Prolunga A: 250 mm B: 55 mm C: 55 mm D: 138 mm
A02423	Extension Prolunga A: 300 mm B: 55 mm C: 55 mm D: 138 mm
A04495	Tilting plate Pialettino basculante A: 77 mm B: 55 mm D: 138 mm

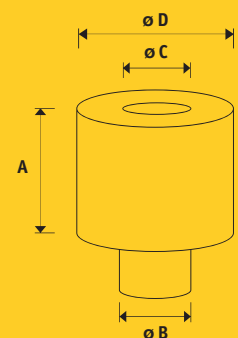







MMUT





2026-01

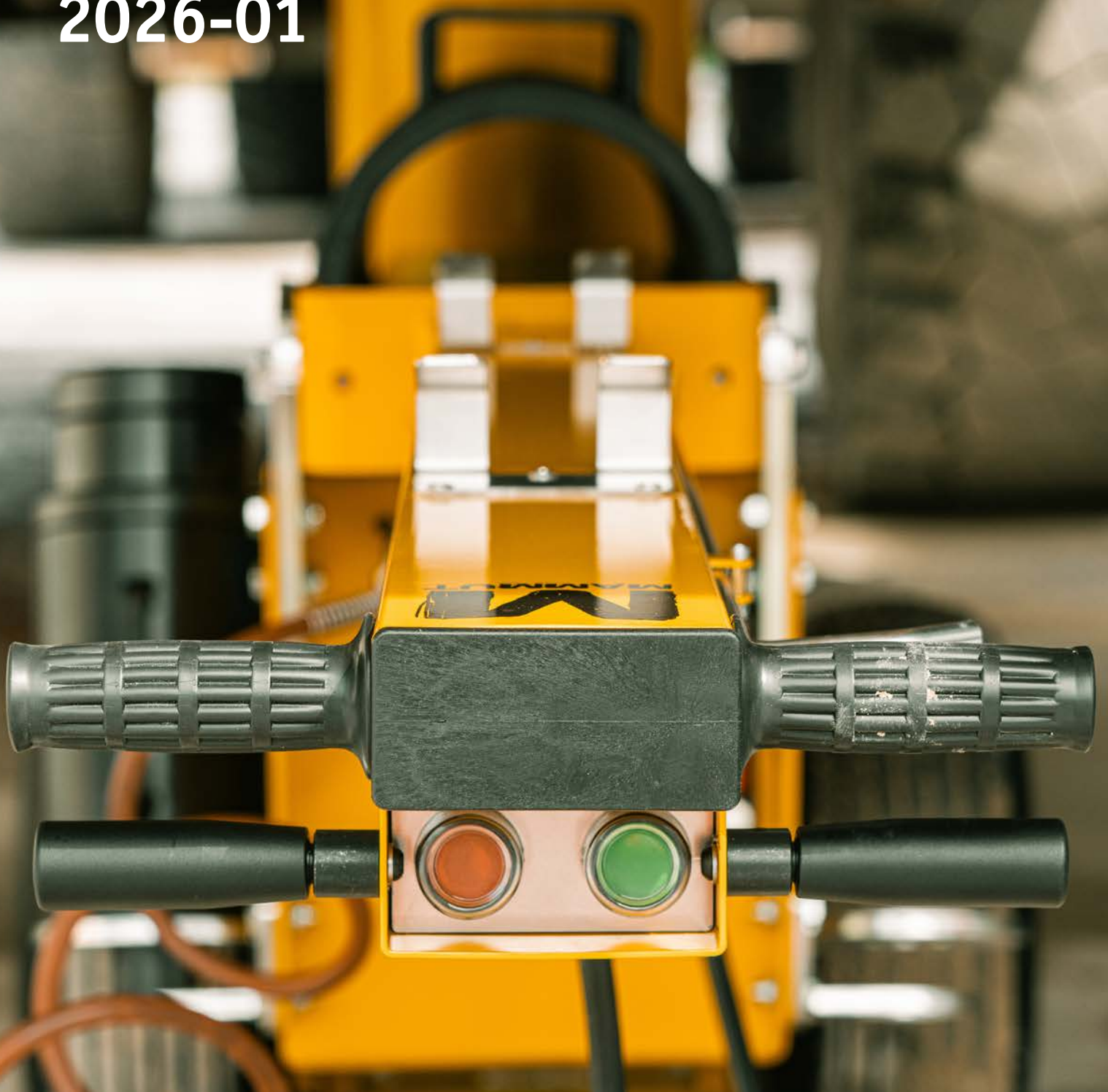

Cattini
OLEOPNEUMATICA

CATTINI OLEOPNEUMATICA S.r.l.
VIA G. VERDI, 41 - Z.I. Vecchia Puglia
42043 GATTATICO (RE) - ITALY
PH. +39 0522 909750 - info@cattini.eu
www.cattini.eu

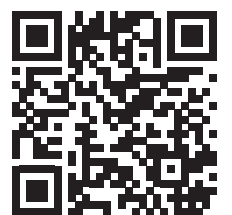

WWW.CATTINI.EU